

## Ventina Twin-Wall

### Short Description

A fully featured professional type log cabin building with double 44mm log walls and 50mm cavity suited to take insulation material (insulation material not supplied). Ideal as a year round home work space. Features high quality "Euro" doors and windows, glazed with 16mm double glazed sealed units. Windows tilt and turn. Features inner roof skin for the purposes of insulation (insulation material not supplied)

### Features

- Double 44mm walls with 50mm cavity
- Twin skinned roof
- Tongue and groove floor and roof boards
- Premium "Euro" 16mm Double Glazed windows and doors
- Double doors with euro cylinder lock
- Adjustable door hinges
- 5.7x5.7m variant features integral porch similar to Malvern

### Optional Features

- Choice of insulation material for wall cavity
- Mineral roll roofing felt
- Bitumous roof shingles
- Canadian Cedar Shingles
- Extra windows
- Professional Installation
- Timber treatment (at time of installation)
- Electrical wiring to NICEIC / Part P

### Key Dimensions

- External size availability 4.3x4.3m  
5.3x5.3m  
5.7x5.7m
- Height to Eaves 2.1m
- Height to Ridge 2.9m

### Timber Thickness Availability

Twin- Wall 44mm

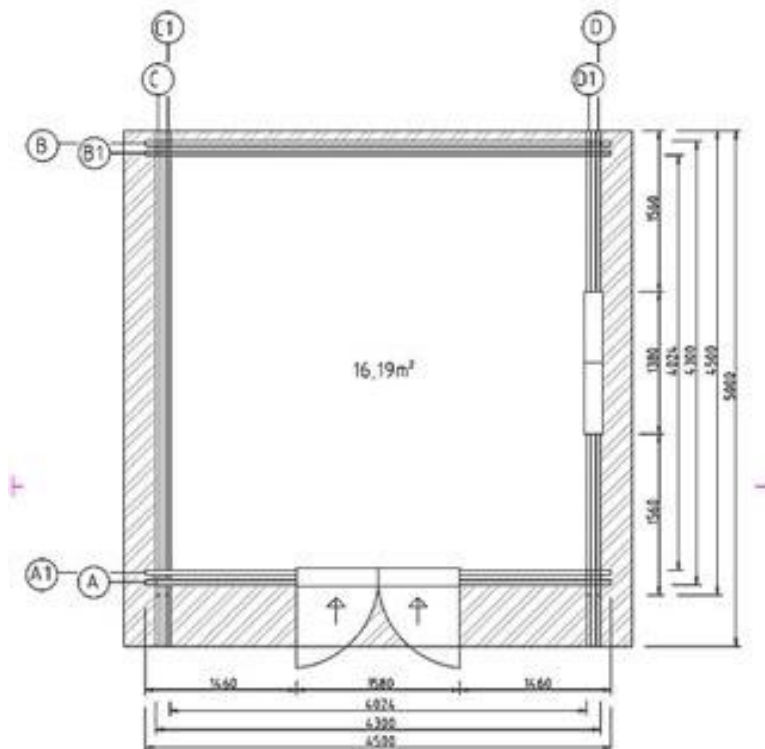

### Ventina Twin-Wall 4.3x4.3 floor plan

Design & specification subject to change without prior notice  
Copyright Ventina Log Cabins

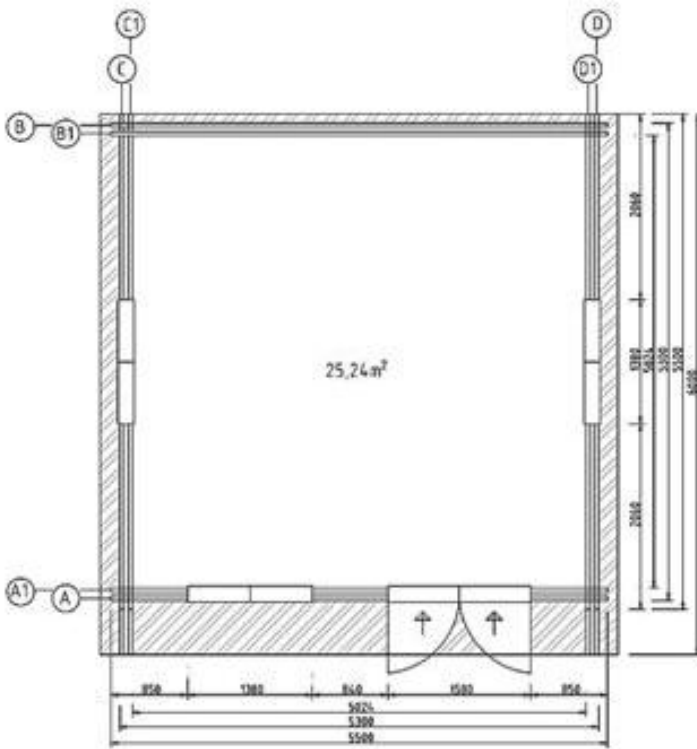

**Ventina Twin-Wall 5.3x5.3 floor plan**

Design & specification subject to change without prior notice  
Copyright Ventina Log Cabins

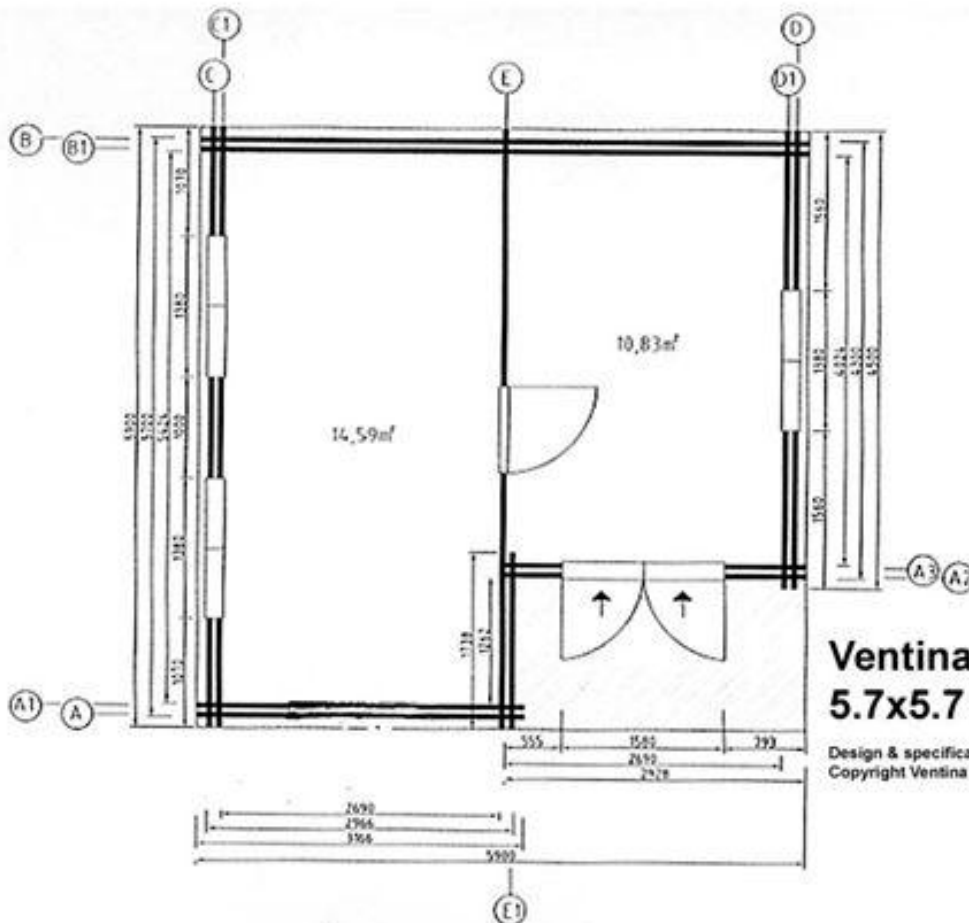

**Ventina Twin-Wall 5.7x5.7 floor plan**

Design & specification subject to change without prior notice  
Copyright Ventina Log Cabins